

SLY.
SLY.
SLY.

STURMEY-ARCHER LTD., NOTTINGHAM

A3 ©

TOLERANCE U.O.S. TO BE AS FOLLOWS:-
 IMPERIAL:- DEC +/- .005 FRAC +/- .010
 METRIC:- 0.XX +/- .1mm 0.X +/- .4mm
 ANGULAR:- +/- 2 DEGREES

ALL DIMENSIONS (U.O.S.) IN - INCHES
 AND ARE FINAL SIZES INCLUDING SURFACE
 FINISH EXCEPT ON STOCK THICKNESS U.O.S.
 FOR EXPLANATION OF DIMENSIONS, NOTES
 AND SYMBOLS ETC. SEE B.S. 308

MATERIAL

HEAT TREATMENT

FINISH

SCALE

2:1

CASE DEPTH

CASE HARDNESS

CORE HARDNESS

DO NOT SCALE
DRAWING

DRAWN

J.A.

DATE

20/1/97

AT POSITION

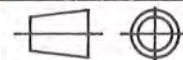

AMENDMENTS

TITLE

AW HUB G.A.

DRG. No. 3270250
(SHEET 2 OF 2)

ISSUED 9345
D0009 08/08/90

OFF

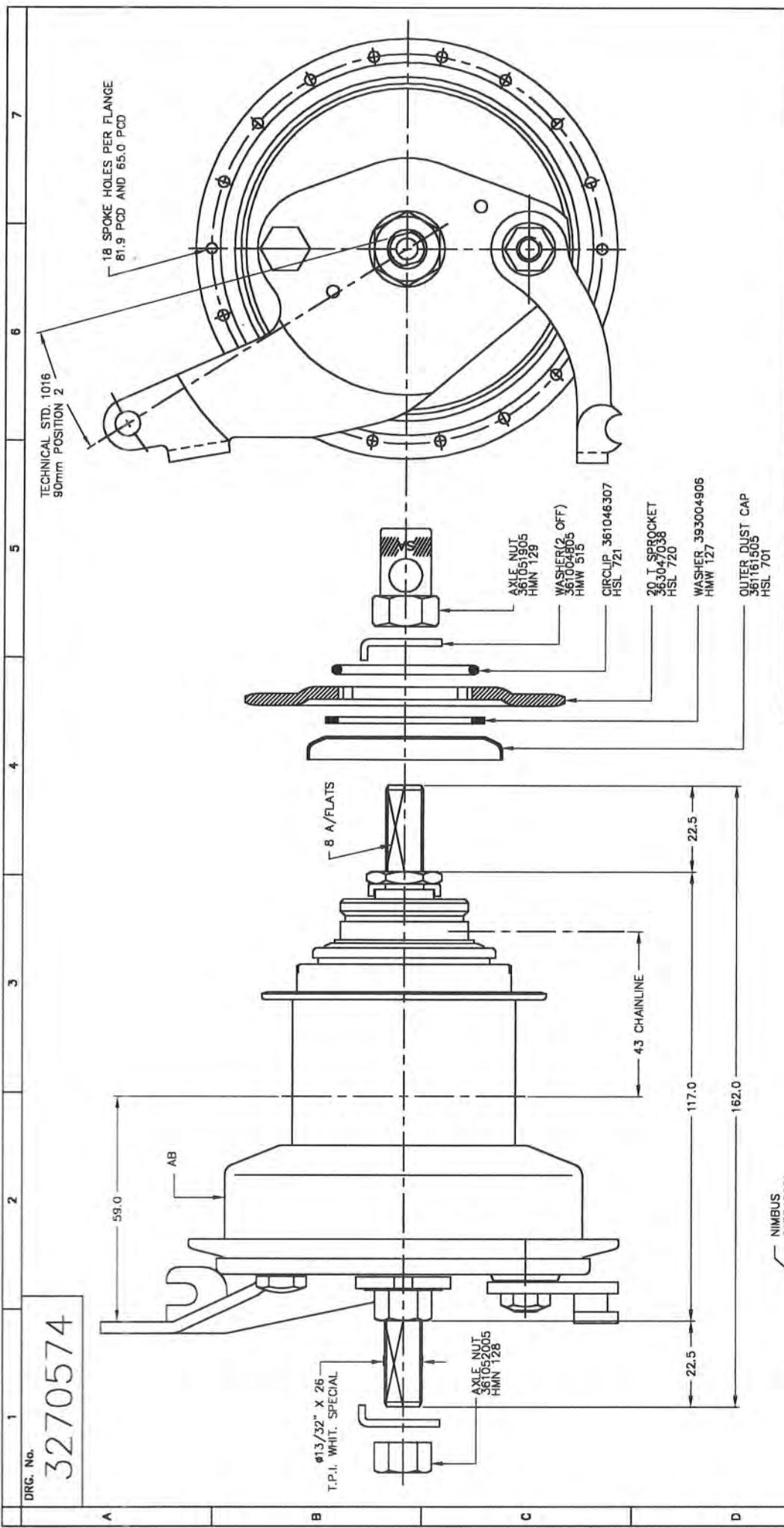

STURMEY-ARCHER LTD., NOTTINGHAM		A3 ©	
TOLERANCE U.O.S. TO BE AS FOLLOWS: - IMPERIAL: - DEC +/- METRIC: - 0.XX +/- ANGULAR: - +/-			
ALL DIMENSIONS (U.O.S.) IN - MILLIMETRES AND ARE FINAL SIZES INCLUDING SURFACE FINISH EXCEPT ON STOCK THICKNESS U.O.S. FOR EXPLANATION OF DIMENSIONS, NOTES AND SYMBOLS ETC. SEE B.S. 308			
MATERIAL	HEAT TREATMENT	FINISH	SCALE
9871		DO NOT SCALE DRAWING	1:1
9816	CASE HARDNESS	AT POSITION	DRAWN
9437	CORE HARDNESS		DATE
8555			16/7/91
8499			
AMENDMENTS		TITLE	
ISSUED	8449	AB + FITTINGS	
00010	09/09/90	ROYAL MAIL SPECIFICATION	
		DRG. No. 3270574	

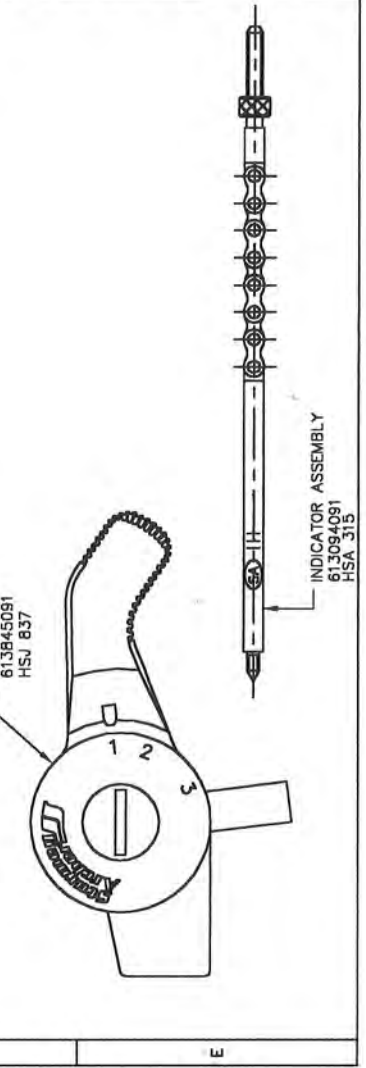

DRG. No.
3270574

1 2 3 4 5 6 7

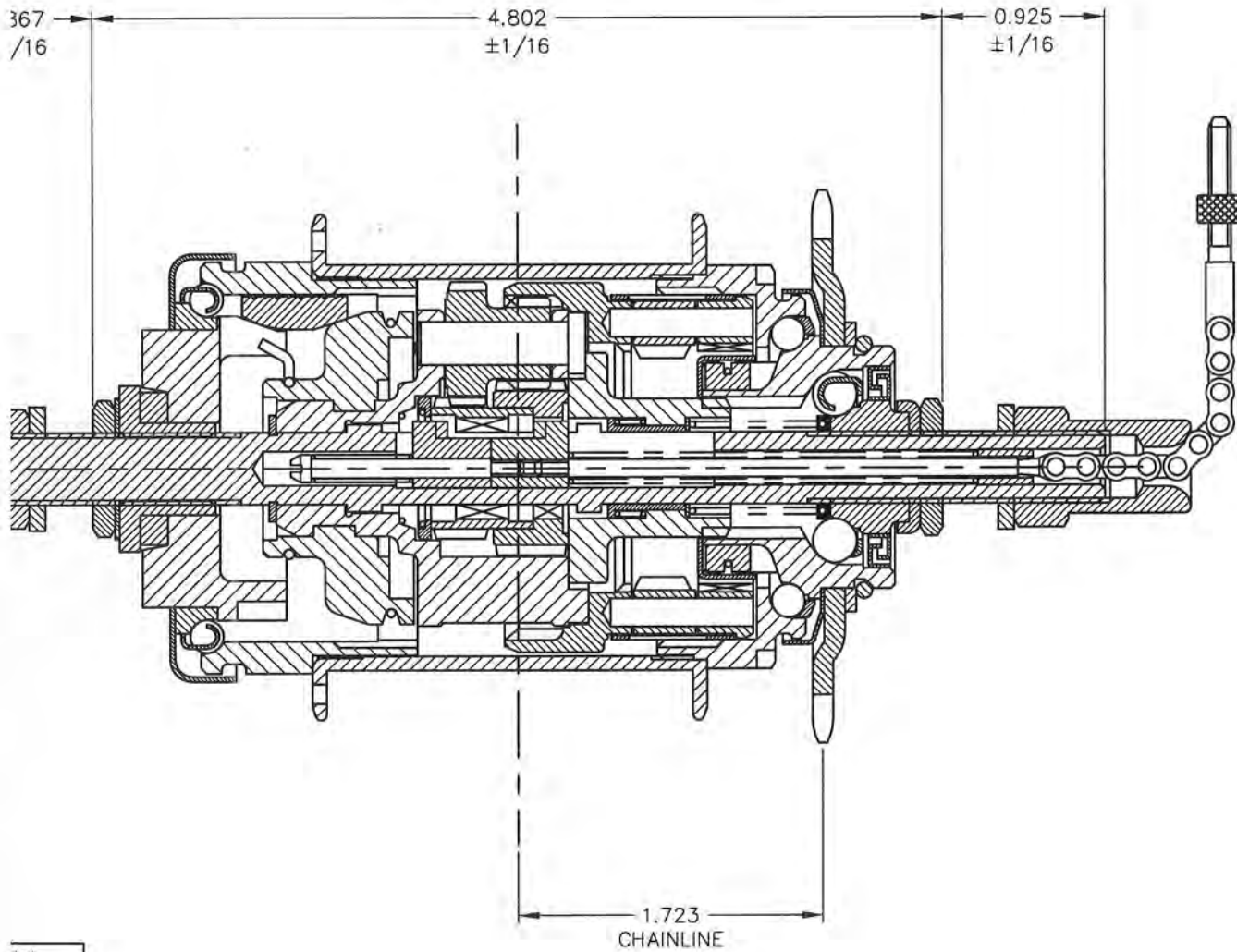

Y.
Y.
Y.
Y.
Y.

STURMEY-ARCHER LTD., NOTTINGHAM

A3 ©

TOLERANCE U.O.S. TO BE AS FOLLOWS: -
 IMPERIAL: - DEC +/- .005 FRAC +/- .010
 METRIC: - 0.XX +/- .1mm 0.X +/- .4mm
 ANGULAR: - +/- 2 DEGREES

ALL DIMENSIONS (U.O.S.) IN - INCHES
 AND ARE FINAL SIZES INCLUDING SURFACE
 FINISH EXCEPT ON STOCK THICKNESS U.O.S.
 FOR EXPLANATION OF DIMENSIONS, NOTES
 AND SYMBOLS ETC. SEE B.S. 308

MATERIAL

9258

HEAT TREATMENT

FINISH

SCALE

2:1

9041

CASE DEPTH

CASE HARDNESS

CORE HARDNESS

DO NOT SCALE
DRAWING

DRAWN

J.A.

8989

DATE

8/2/93

8706

AT POSITION

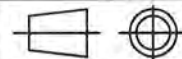

AMENDMENTS

TITLE

5 SPEED COASTER
(SINGLE CABLE)

DRG. No.

3270594
SHEET 3 OF 3

ISSUED 8595
D0009 08/08/90

F

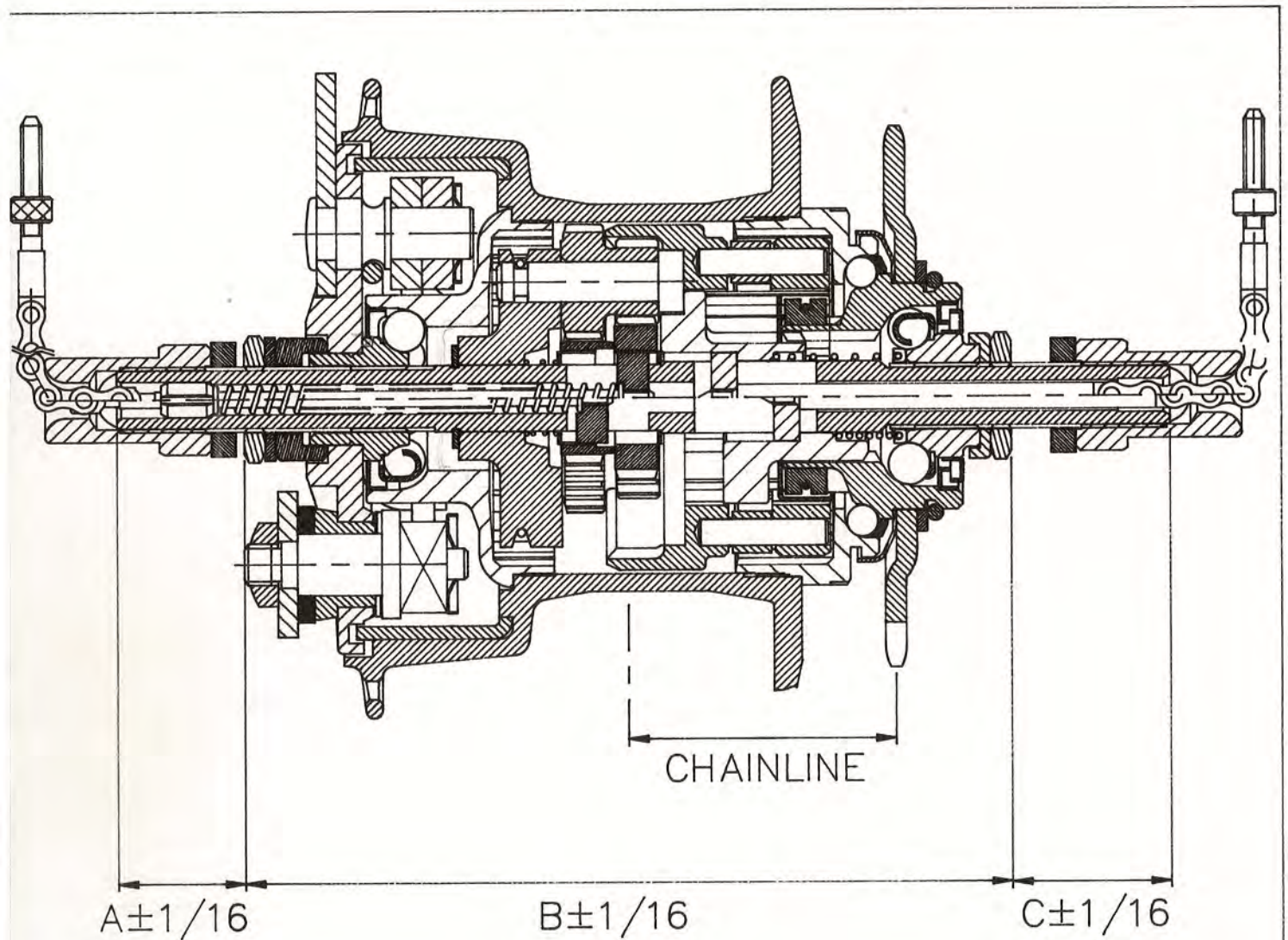

GEAR RATIOS: - 1 SUPER LOW - 33% DECREASE
 2 LOW - 21% DECREASE
 3 NORMAL - DIRECT DRIVE
 4 HIGH - 26 2/3% INCREASE
 5 SUPER HIGH - 50% INCREASE

STURMEY-ARCHER LTD., NOTTINGHAM				A3 ©	
TOLERANCE U.O.S. TO BE AS FOLLOWS: - IMPERIAL: - DEC +/- .005 FRAC +/- .010 METRIC: - 0.XX +/- .1mm 0.X +/- .4mm ANGULAR: - +/- 2 DEGREES			ALL DIMENSIONS (U.O.S.) IN - INCHES AND ARE FINAL SIZES INCLUDING SURFACE FINISH EXCEPT ON STOCK THICKNESS U.O.S. FOR EXPLANATION OF DIMENSIONS, NOTES AND SYMBOLS ETC. SEE B.S. 308		
MATERIAL _____			HEAT TREATMENT _____	FINISH 91	SCALE 2:1
CASE DEPTH	CASE HARDNESS	CORE HARDNESS	DO NOT SCALE DRAWING	DRAWN J.A.	DATE 23/11/92
_____	_____	_____		AT POSITION ∇	
TITLE AT5 GENERAL ARRANGEMENT (HEADED BRAKE CAM)			DRG. No. SHEET 3 OF 3 3270588		
AMENDMENTS					
ISSUED	8552				
D0009	08/08/90				

DRG. No.

3610290

A

B

C

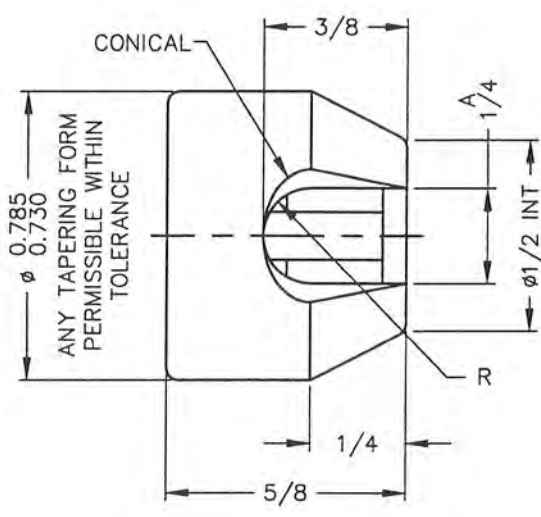
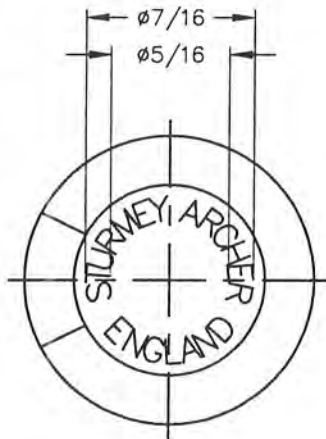
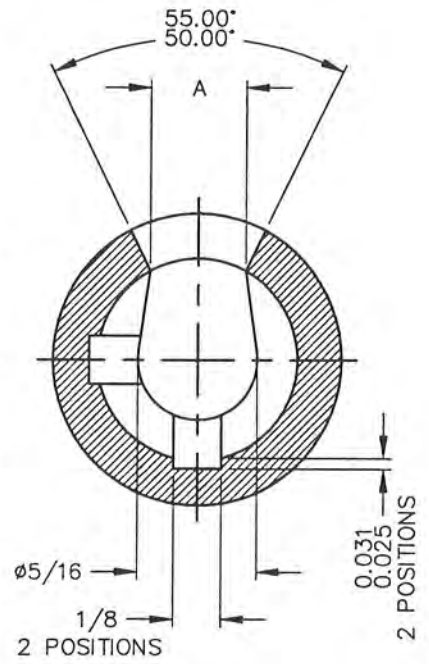
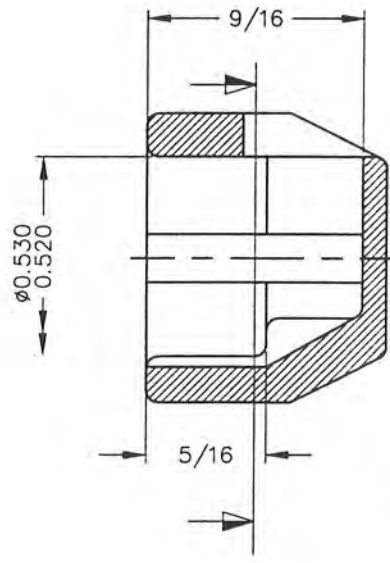

ALL UNDIMENSIONED RADII 1/32

1760	STURMEY-ARCHER LTD., NOTTINGHAM			A4 ©
3456	TOLERANCE U.O.S. TO BE AS FOLLOWS:-		ALL DIMENSIONS (U.O.S.) IN - INCHES	
4868	IMPERIAL:- DEC +/- .005 FRAC +/- .010		AND ARE FINAL SIZES INCLUDING SURFACE	
5293	METRIC:- 0.XX +/- .1mm 0.X +/- .4mm		FINISH EXCEPT ON STOCK THICKNESS U.O.S.	
5522	ANGULAR:- +/- 2 DEGREES		FOR EXPLANATION OF DIMENSIONS, NOTES	
7757	MATERIAL M319-1 (NATURAL POLYTHENE)		AND SYMBOLS ETC. SEE B.S. 308	
8455	HEAT TREATMENT		FINISH 00	SCALE 2:1
9606	CASE DEPTH	CASE HARDNESS	DO NOT SCALE DRAWING	DRAWN NICK.G
				DATE 25/3/92
	AT POSITION ▽			
AMENDMENTS	TITLE			DRG. No.
ISSUED 1753	INDICATOR GUARD			3610290
00007 08/08/90				